

- **Monolithic Silicon IC Containing Photodiode, Operational Amplifier, and Feedback Components**
- **Converts Light Intensity to Output Voltage**
- **High Irradiance Responsivity Typically 80 mV/($\mu\text{W}/\text{cm}^2$) at $\lambda_p = 880 \text{ nm}$ (TSL250)**
- **Compact 3-Leaded Clear Plastic Package**
- **Low Dark (Offset) Voltage . . . 10 mV Max at 25°C, $V_{DD} = 5 \text{ V}$**
- **Single-Supply Operation**
- **Wide Supply-Voltage Range . . . 3 V to 9 V**
- **Low Supply Current . . . 800 μA Typical at $V_{DD} = 5 \text{ V}$**
- **Advanced LinCMOS™ Technology**

description

The TSL250, TSL251, and TSL252 are light-to-voltage optical sensors, each combining a photodiode and a transimpedance amplifier (feedback resistor = 16 M Ω , 8 M Ω , and 2 M Ω respectively) on a single monolithic IC. The output voltage is directly proportional to the light intensity (irradiance) on the photodiode. These devices utilize Texas Instruments silicon-gate LinCMOS™ technology, which provides improved amplifier offset-voltage stability and low power consumption.

functional block diagram

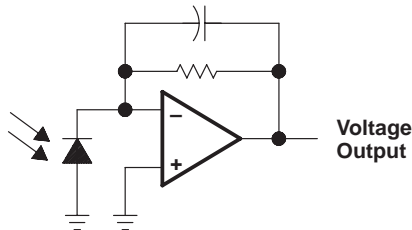

absolute maximum ratings over operating free-air temperature range (unless otherwise noted)†

Supply voltage, V_{DD} (see Note 1)	10 V
Output current, I_O	$\pm 10 \text{ mA}$
Duration of short-circuit current at (or below) 25°C (see Note 2)	5 s
Operating free-air temperature range, T_A	–25°C to 85°C
Storage temperature range, T_{stg}	–25°C to 85°C
Lead temperature 1,6 mm (1/16 inch) from case for 10 seconds	240°C

† Stresses beyond those listed under “absolute maximum ratings” may cause permanent damage to the device. These are stress ratings only, and functional operation of the device at these or any other conditions beyond those indicated under “recommended operating conditions” is not implied. Exposure to absolute-maximum-rated conditions for extended periods may affect device reliability.

- NOTES: 1. All voltages are with respect to GND.
2. Output may be shorted to supply.

recommended operating conditions

	MIN	NOM	MAX	UNIT
Supply voltage, V_{DD}	3	5	9	V
Operating free-air temperature, T_A	0		70	°C



Please be aware that an important notice concerning availability, standard warranty, and use in critical applications of Texas Instruments semiconductor products and disclaimers thereto appears at the end of this data sheet.

LinCMOS is a trademark of Texas Instruments Incorporated.

PRODUCTION DATA information is current as of publication date. Products conform to specifications per the terms of Texas Instruments standard warranty. Production processing does not necessarily include testing of all parameters.



TSL250, TSL251, TSL252 LIGHT-TO-VOLTAGE OPTICAL SENSORS

SOES004C – AUGUST 1991 – REVISED NOVEMBER 1995

electrical characteristics at $V_{DD} = 5\text{ V}$, $T_A = 25^\circ\text{C}$, $\lambda_p = 880\text{ nm}$, $R_L = 10\text{ k}\Omega$ (unless otherwise noted) (see Note 3)

PARAMETER	TEST CONDITIONS	TSL250			TSL251			TSL252			UNIT
		MIN	TYP	MAX	MIN	TYP	MAX	MIN	TYP	MAX	
V_D Dark voltage	$E_e = 0$		3	10		3	10		3	10	mV
V_{OM} Maximum output voltage swing	$E_e = 2\text{ mW/cm}^2$	3.1	3.5		3.1	3.5		3.1	3.5		V
V_O Output voltage	$E_e = 25\text{ }\mu\text{W/cm}^2$	1	2	3							V
	$E_e = 45\text{ }\mu\text{W/cm}^2$				1	2	3				
	$E_e = 285\text{ }\mu\text{W/cm}^2$							1	2	3	
α_{vo} Temperature coefficient of output voltage (V_O)	$E_e = 25\text{ }\mu\text{W/cm}^2$, $T_A = 0^\circ\text{C to } 70^\circ\text{C}$		± 1								mV/ $^\circ\text{C}$
	$E_e = 45\text{ }\mu\text{W/cm}^2$, $T_A = 0^\circ\text{C to } 70^\circ\text{C}$				± 1						
	$E_e = 285\text{ }\mu\text{W/cm}^2$, $T_A = 0^\circ\text{C to } 70^\circ\text{C}$							± 1			
N_e Irradiance responsivity	See Note 4		80			45			7		mV/($\mu\text{W/cm}^2$)
I_{DD} Supply current	$E_e = 25\text{ }\mu\text{W/cm}^2$		900	1600							μA
	$E_e = 45\text{ }\mu\text{W/cm}^2$					900	1600				
	$E_e = 285\text{ }\mu\text{W/cm}^2$								900	1600	

NOTES: 3. The input irradiance E_e is supplied by a GaAlAs infrared-emitting diode with $\lambda_p = 880\text{ nm}$.
4. Irradiance responsivity is characterized over the range $V_O = 0.05\text{ to } 3\text{ V}$.

operating characteristics at $T_A = 25^\circ\text{C}$ (see Figure 1)

PARAMETER	TEST CONDITIONS	TSL250			TSL251			TSL252			UNIT
		MIN	TYP	MAX	MIN	TYP	MAX	MIN	TYP	MAX	
t_r Output pulse rise time	$V_{DD} = 5\text{ V}$, $\lambda_p = 880\text{ nm}$		360			90			7		μs
t_f Output pulse fall time	$V_{DD} = 5\text{ V}$, $\lambda_p = 880\text{ nm}$		360			90			7		μs
V_n Output noise voltage	$V_{DD} = 5\text{ V}$, $f = 20\text{ Hz}$		0.6			0.5			0.4		$\mu\text{V}/\sqrt{\text{Hz}}$

PARAMETER MEASUREMENT INFORMATION

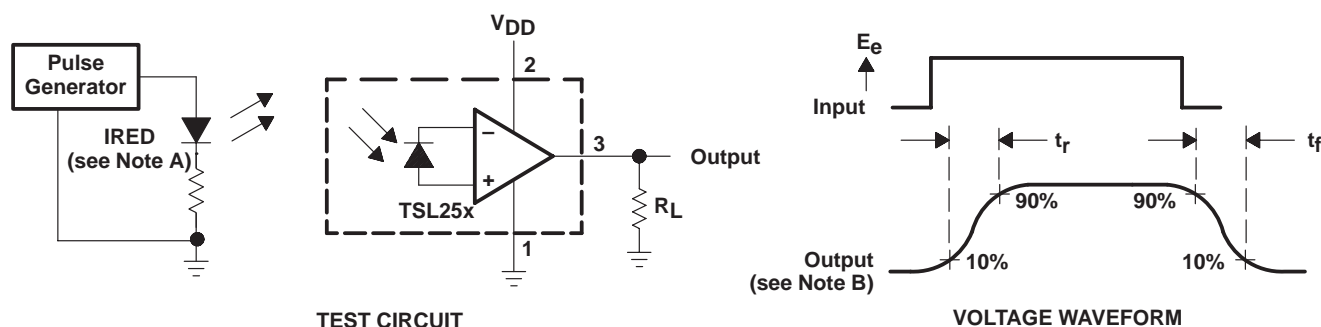

NOTES: A. The input irradiance is supplied by a pulsed GaAlAs infrared-emitting diode with the following characteristics: $\lambda_p = 880\text{ nm}$, $t_r < 1\text{ }\mu\text{s}$, $t_f < 1\text{ }\mu\text{s}$.
B. The output waveform is monitored on an oscilloscope with the following characteristics: $t_r < 100\text{ ns}$, $Z_i \geq 1\text{ MHz}$, $C_i \leq 20\text{ pF}$.

Figure 1. Switching Times

TYPICAL CHARACTERISTICS

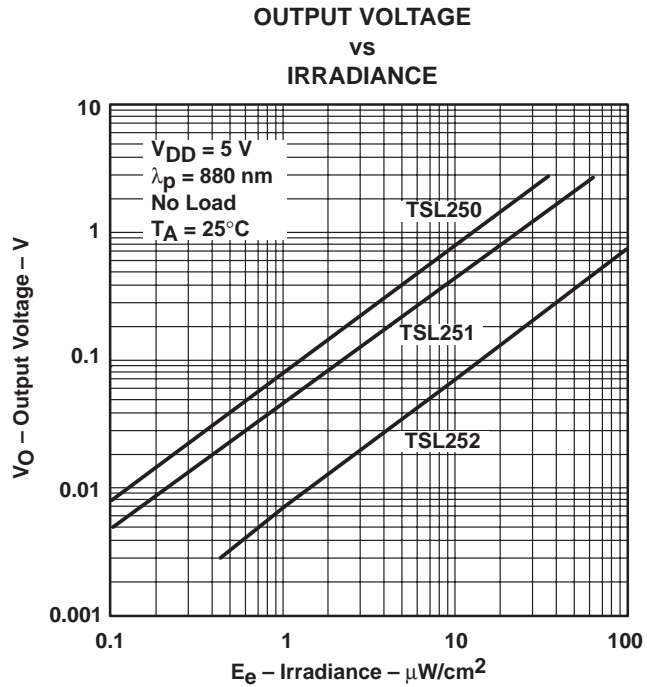

Figure 2

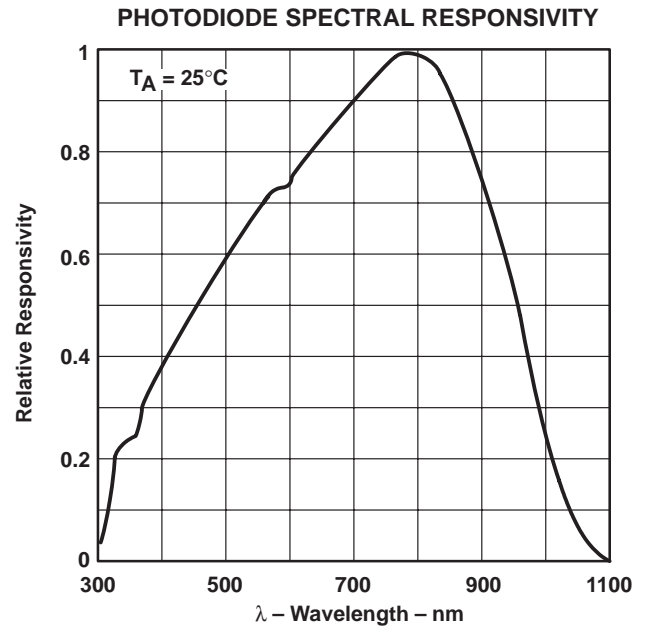

Figure 3

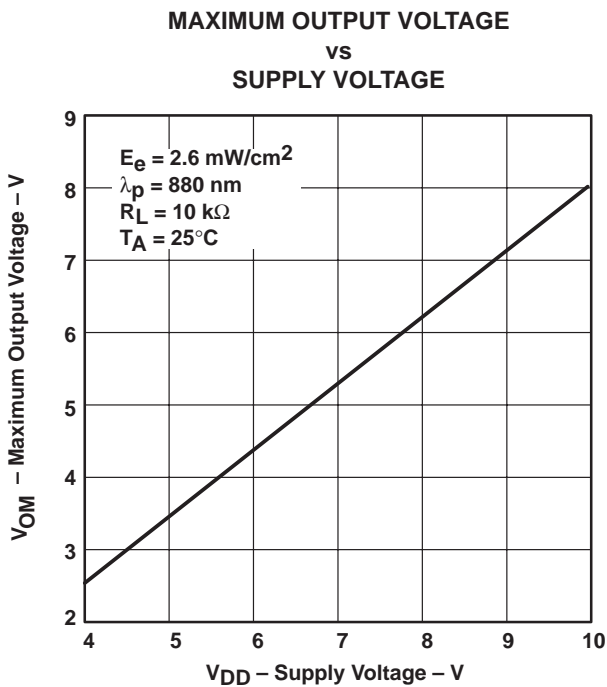

Figure 4

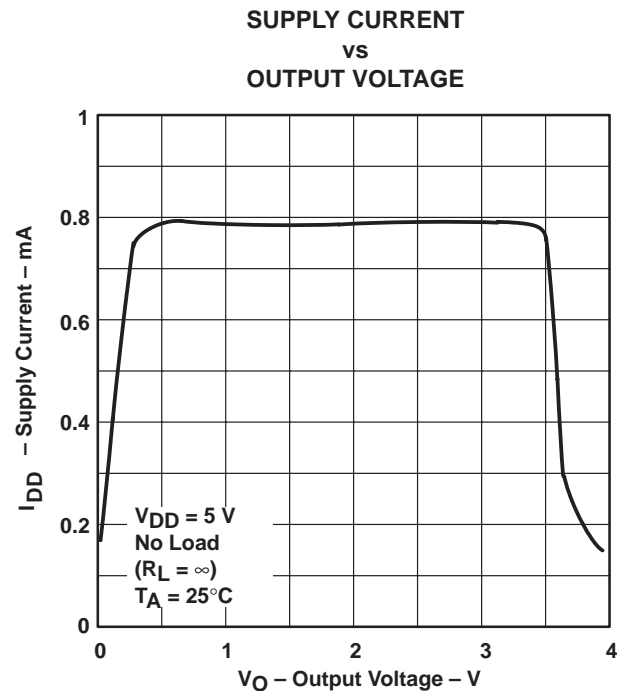

Figure 5

TSL250, TSL251, TSL252 LIGHT-TO-VOLTAGE OPTICAL SENSORS

SOES004C – AUGUST 1991 – REVISED NOVEMBER 1995

TYPICAL CHARACTERISTICS

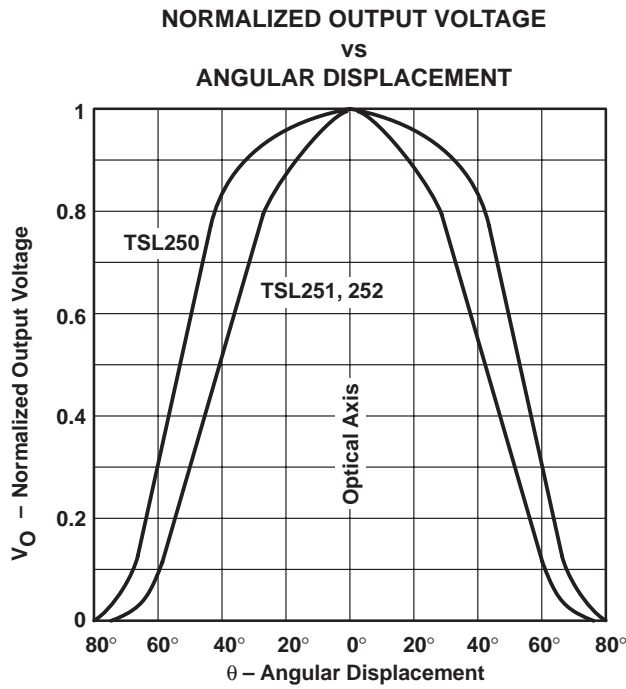
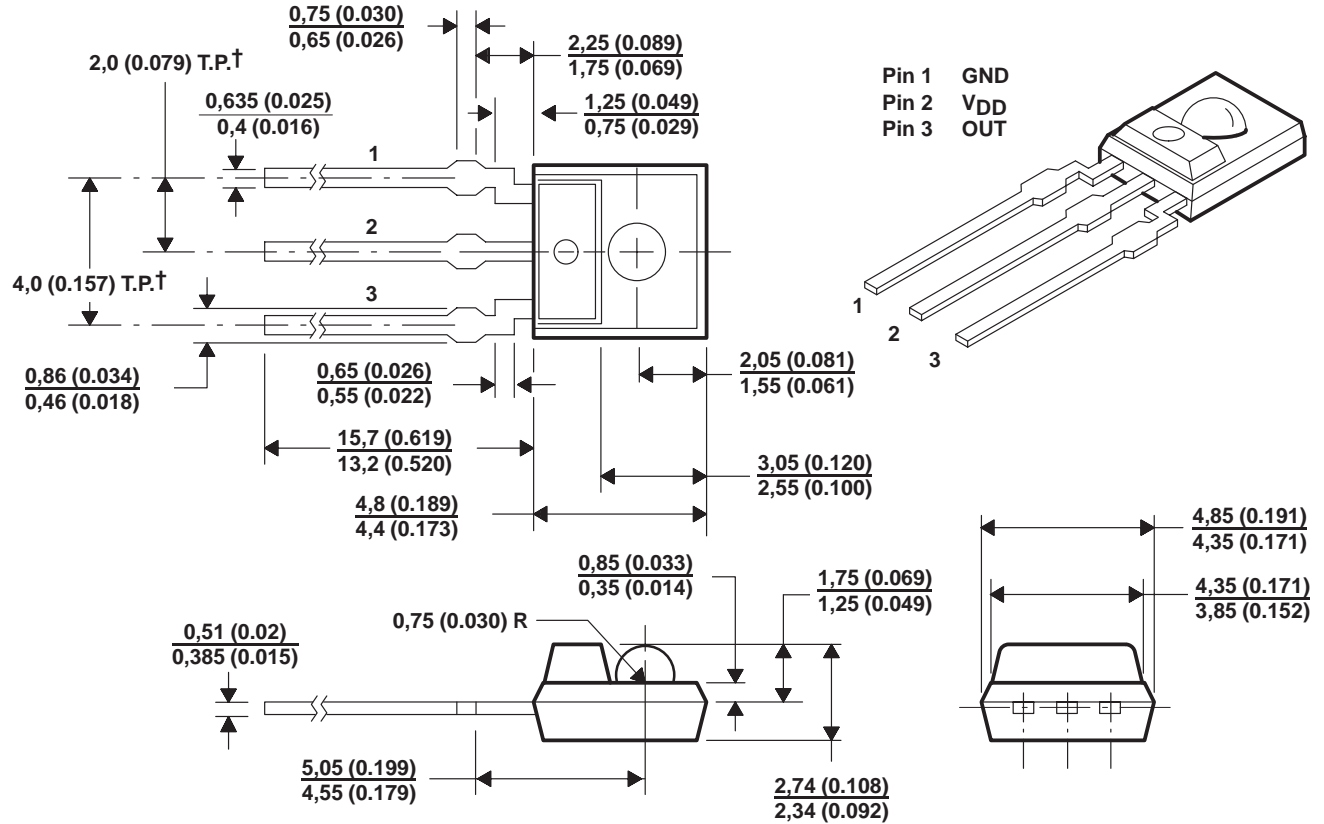

Figure 6

APPLICATION INFORMATION

The photodiode/amplifier chip is packaged in a clear plastic three-leaded package. The integrated photodiode active area is typically 1,0 mm² (0.0016 in²) for TSL250, 0,5 mm² (0.00078 in²) for the TSL251, and 0,26 mm² (0.0004 in²) for the TSL252.



† True position when unit is installed.

- NOTES: A. All linear dimensions are in millimeters (inches).
B. This drawing is subject to change without notice.

Figure 7. Mechanical Data

IMPORTANT NOTICE

Texas Instruments and its subsidiaries (TI) reserve the right to make changes to their products or to discontinue any product or service without notice, and advise customers to obtain the latest version of relevant information to verify, before placing orders, that information being relied on is current and complete. All products are sold subject to the terms and conditions of sale supplied at the time of order acknowledgement, including those pertaining to warranty, patent infringement, and limitation of liability.

TI warrants performance of its semiconductor products to the specifications applicable at the time of sale in accordance with TI's standard warranty. Testing and other quality control techniques are utilized to the extent TI deems necessary to support this warranty. Specific testing of all parameters of each device is not necessarily performed, except those mandated by government requirements.

CERTAIN APPLICATIONS USING SEMICONDUCTOR PRODUCTS MAY INVOLVE POTENTIAL RISKS OF DEATH, PERSONAL INJURY, OR SEVERE PROPERTY OR ENVIRONMENTAL DAMAGE ("CRITICAL APPLICATIONS"). TI SEMICONDUCTOR PRODUCTS ARE NOT DESIGNED, AUTHORIZED, OR WARRANTED TO BE SUITABLE FOR USE IN LIFE-SUPPORT DEVICES OR SYSTEMS OR OTHER CRITICAL APPLICATIONS. INCLUSION OF TI PRODUCTS IN SUCH APPLICATIONS IS UNDERSTOOD TO BE FULLY AT THE CUSTOMER'S RISK.

In order to minimize risks associated with the customer's applications, adequate design and operating safeguards must be provided by the customer to minimize inherent or procedural hazards.

TI assumes no liability for applications assistance or customer product design. TI does not warrant or represent that any license, either express or implied, is granted under any patent right, copyright, mask work right, or other intellectual property right of TI covering or relating to any combination, machine, or process in which such semiconductor products or services might be or are used. TI's publication of information regarding any third party's products or services does not constitute TI's approval, warranty or endorsement thereof.